



Preliminary Steps:

1. Read all instructions carefully and study diagrams before installing the LED bar.
2. Check with state and local authorities for laws governing usage and proper mounting of auxiliary lights.
3. Disconnect ground connection from battery (marked “-”) to avoid accidental short circuits before attempting to connect electrical wires.
4. Route new wires along existing wiring. Tape as necessary to correct slack.
5. When running wires through the firewall, keep them away from moving parts.

Mounting Lights:

1. Drill 8.5mm holes for screw placement on the surface where you would like to fix the bar.
2. Use the bolt to fasten the lamp, add the locking washer and tighten the bolt.
3. Wiring:
 Black: Driving light “-”
 Red: Driving light “+”

Note:

1. Powerboost (offroad mode): Remove the internal fuse next to the ATP connector.
2. ECE R112 approved mode: Insert the internal fuse next to the ATP connector.

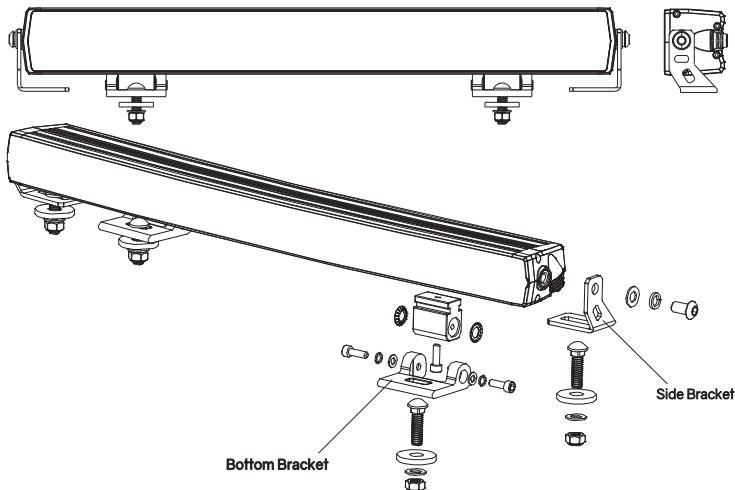

Warning:

1. Works under the specified voltage (DC9-36V).
2. This LED bar becomes hot under continuous use. Don't remove or touch the casing for at least 30 minutes after turning the bar off.
3. Keep the heat-sink clean and exposed to maintain air flow.